

Retail

Advantages

- A perfect solution to properly display your product.
- Customization options to achieve the vision you have for your brand
- Improving presentation with turnkey quality marketing solutions
- The ability to fully wrap/brand your FORT allows for the ideal look to your activation
- Decide the most effective way to reach customers with our interchangeable wall options
- Set up unique and effective displays with our turnkey furnishing package
- Provide escape from outside elements with our climate-controlled units
- 16ft wide footprint to maximize useable space
- Keypad lock system
- Flexible layouts for interior/exterior, entrance and windows
- Built-in Coax & HDMI connections

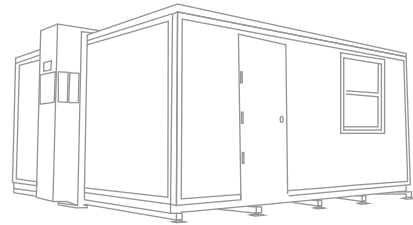



Up To 180 Mph

Up To 4 FORTS Units Per Truck

Leveled+ Assembled On Any Surface

Built-in HVAC, Lighting, Data, Power Outlets

Energy Efficiency + Environmentally Friendly

Rapid 15 Minutes Set-up

Easily Maneuverable

4,000 lbs per FORTS Unit

Branding Options Available

FORTS SYSTEMS

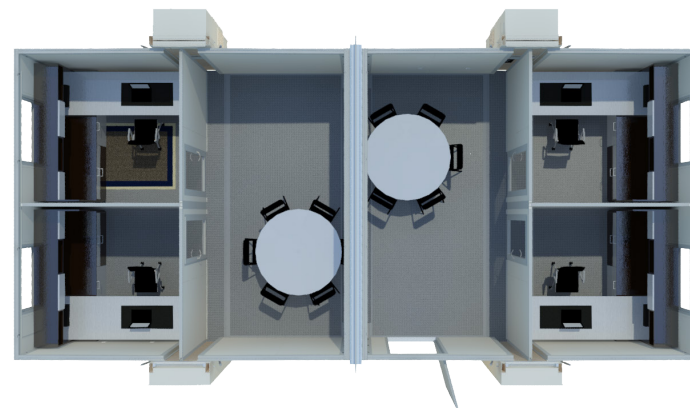

MULTIPLE INTERIOR LAYOUT OPTIONS

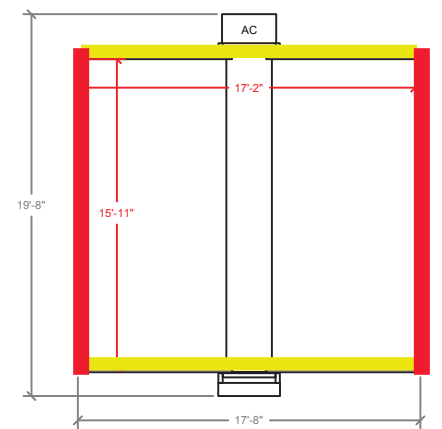

SINGLE UNIT

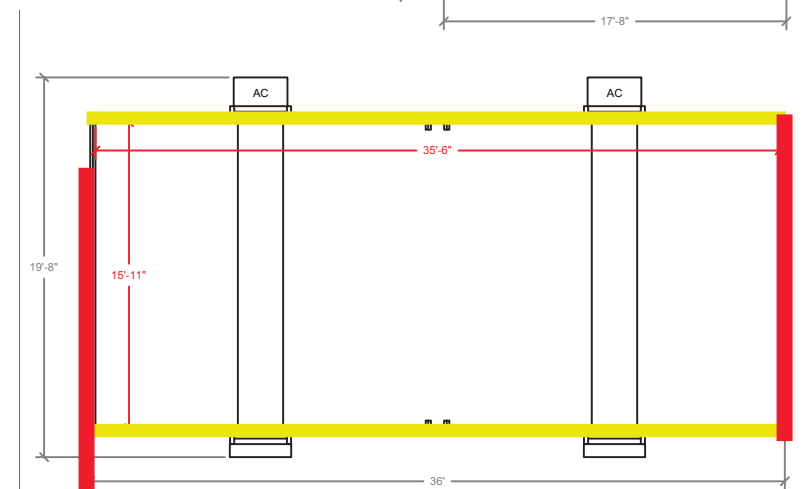

TANDEM

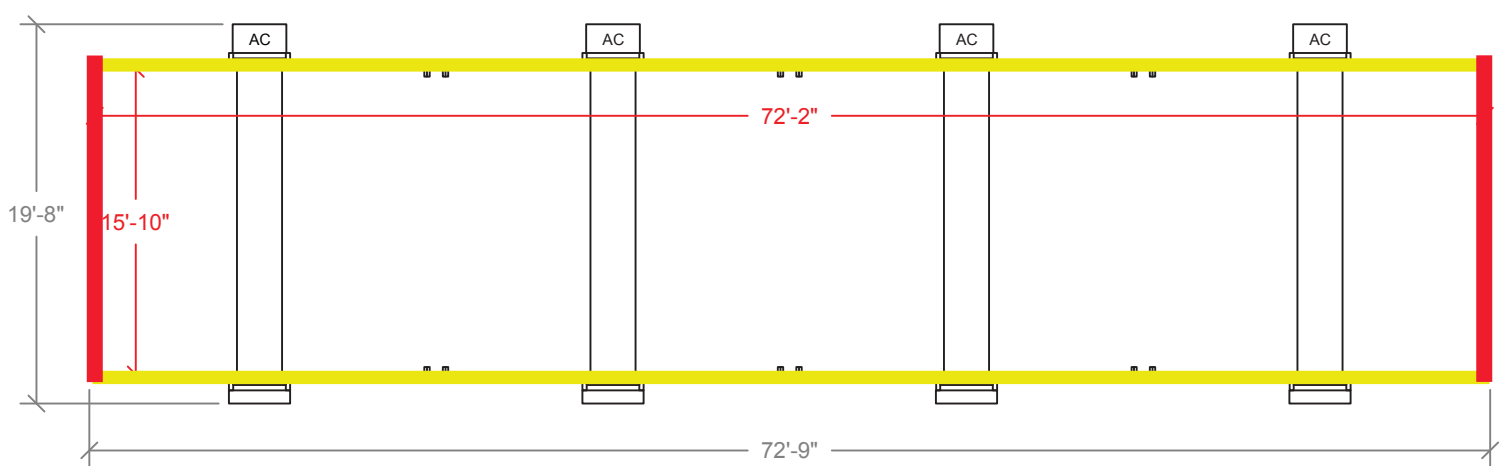
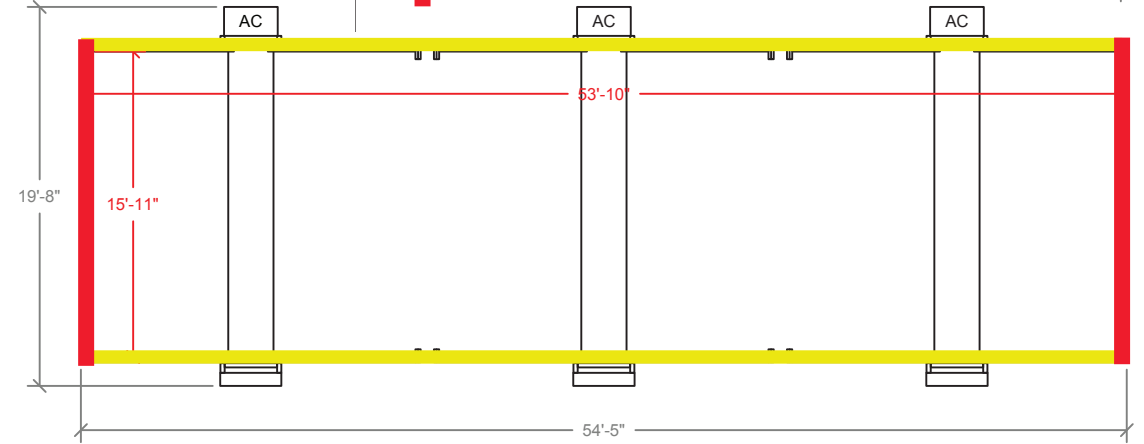

ALPHA WALL



BETA WALL

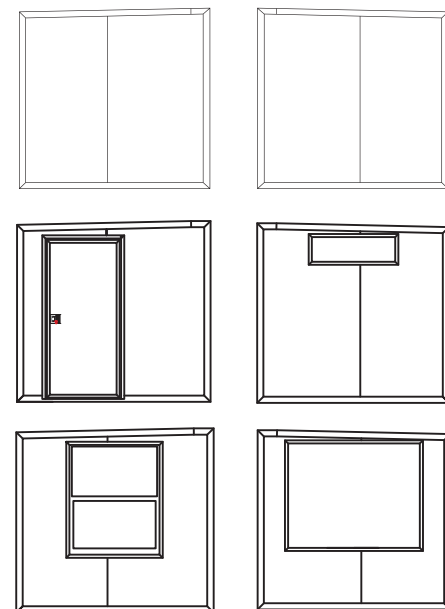

CONTACT US (786) 942 - 4389 | info@fortsservices.com | fortsservices.com