

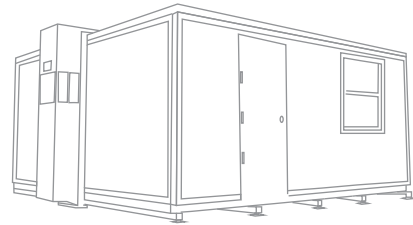

# Recovery

## Advantages

- Ample room for stretching or massage tables
- Receptacles for any equipment needed
- 16ft wide footprint to maximize furniture layout
- Keypad lock system
- Optional furniture packages
- Flexible layouts for interior/exterior, entrance and windows
- Built-in Coax & HDMI connections
- Secure storage options
- Ramp and step options



Up To 180 Mph

Up To 4 FORTS Units Per Truck

Leveled+ Assembled On Any Surface

Built-in HVAC, Lighting, Data, Power Outlets

Energy Efficiency + Environmentally Friendly

Rapid 15 Minutes Set-up

Easily Maneuverable

4,000 lbs per FORTS Unit

Branding Options Available

# FORTS SYSTEMS

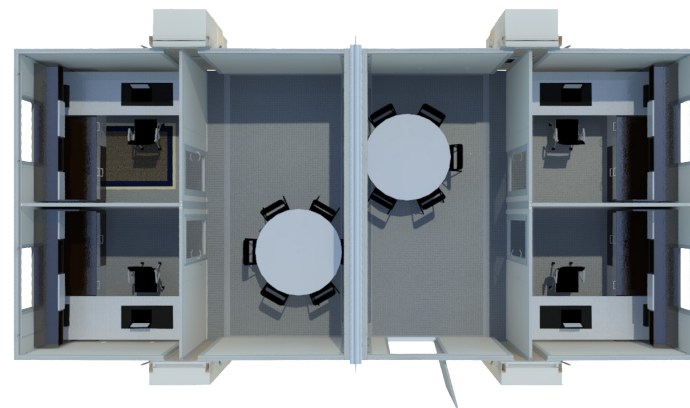

MULTIPLE INTERIOR LAYOUT OPTIONS

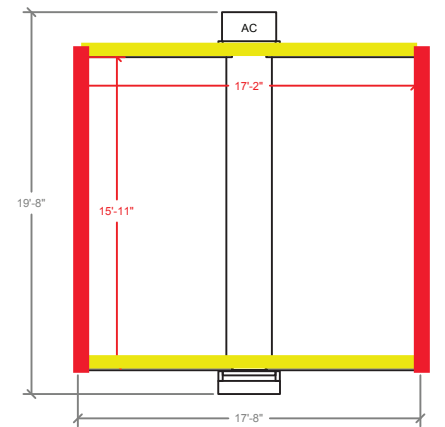

SINGLE UNIT

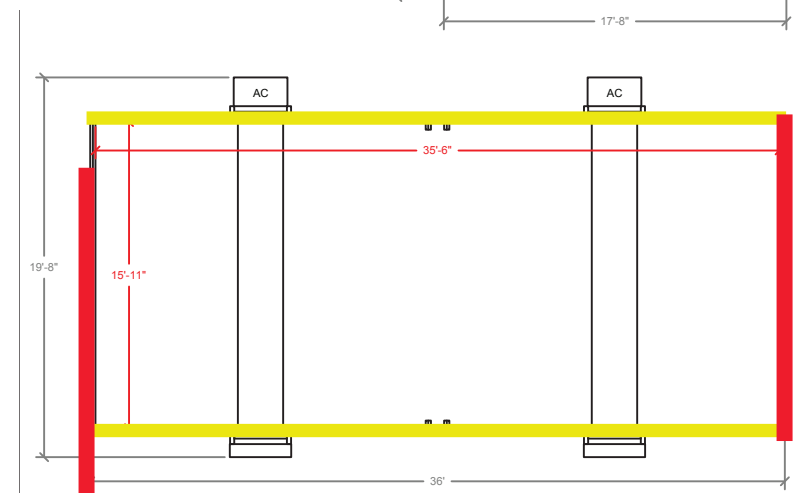

TANDEM

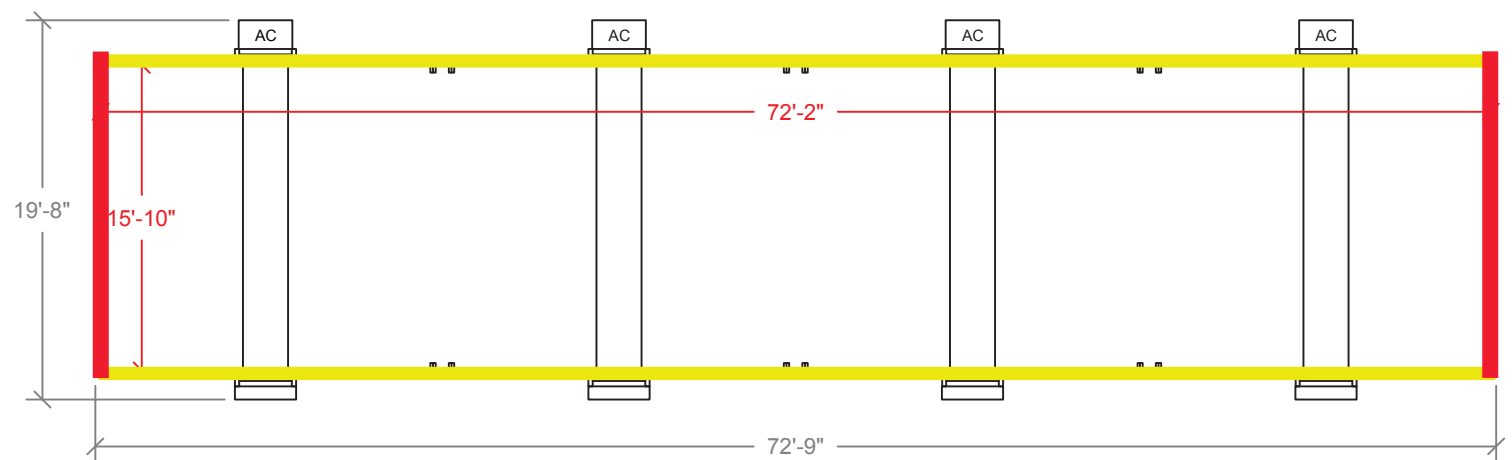
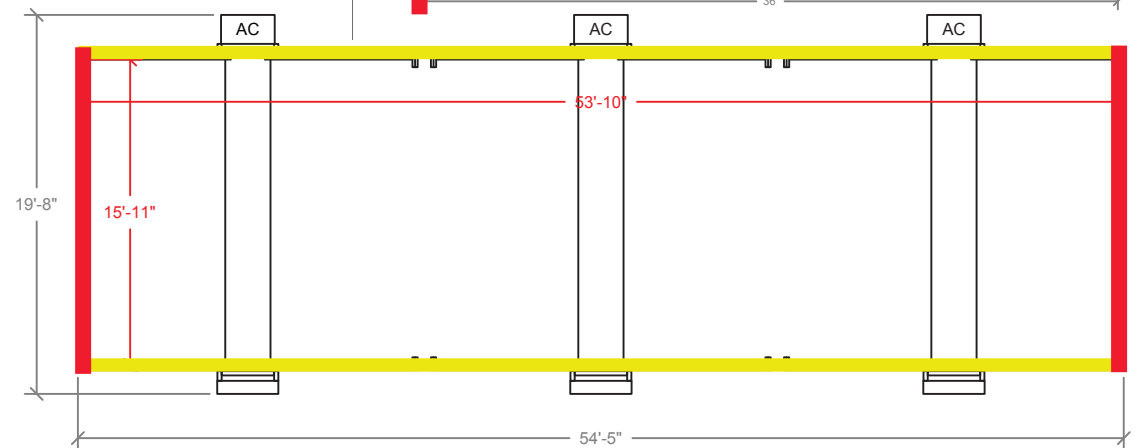

## ALPHA WALL



## BETA WALL



CONTACT US (786) 942 - 4389 | info@fortsservices.com | fortsservices.com