

Medical Archives

Advantages

- *Insulated walls to dampen outside noise*
- *16'x16' interior footprint to maximize layout possibilities*
- *Our quality control process allows for a clean and sterile unit*
- *Keypad lock system*
- *Built-in Coax & HDMI connections*
- *Additional pass-throughs for large wires*
- *Secure storage options*
- *Optional furniture packages*
- *Ramp and step options*
- *Our quality control process allows for a clean and sterile unit*
- *2-ton HVAC for a climate-controlled environment*
- *Insulated/ thermally broken panels to maintain temperature*

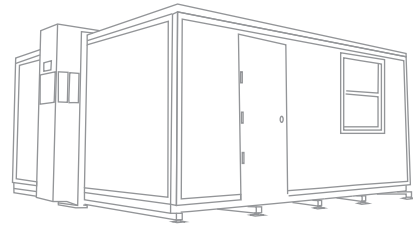



Up To 180 Mph

Up To 4 FORTS Units Per Truck

Leveled+ Assembled On Any Surface

Built-in HVAC, Lighting, Data, Power Outlets

Energy Efficiency + Environmentally Friendly

Rapid 15 Minutes Set-up

Easily Maneuverable

4,000 lbs per FORTS Unit

Branding Options Available

FORTS SYSTEMS

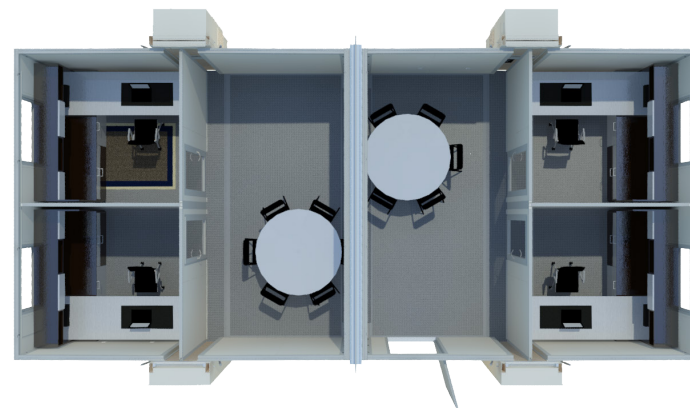

MULTIPLE INTERIOR LAYOUT OPTIONS

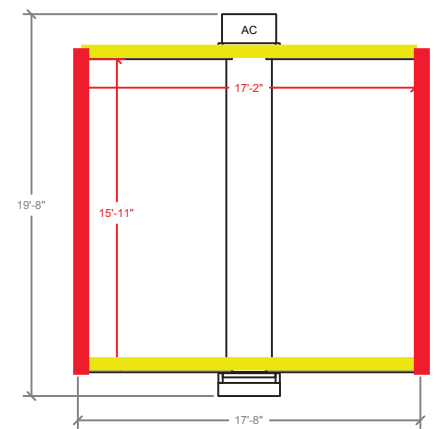

SINGLE UNIT

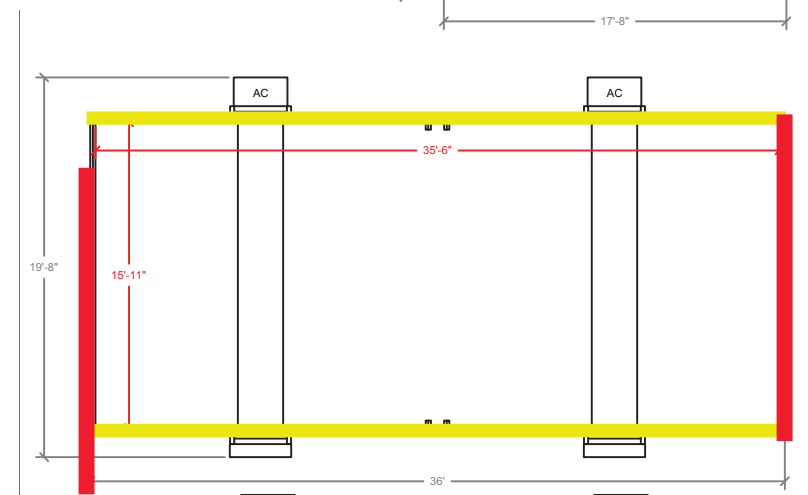

TANDEM

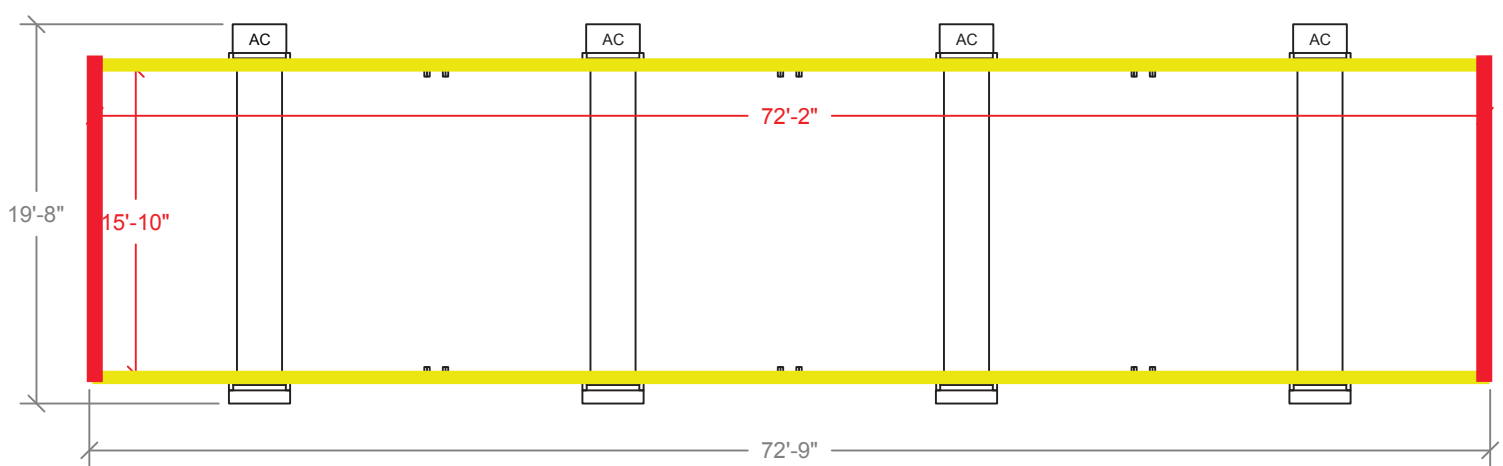
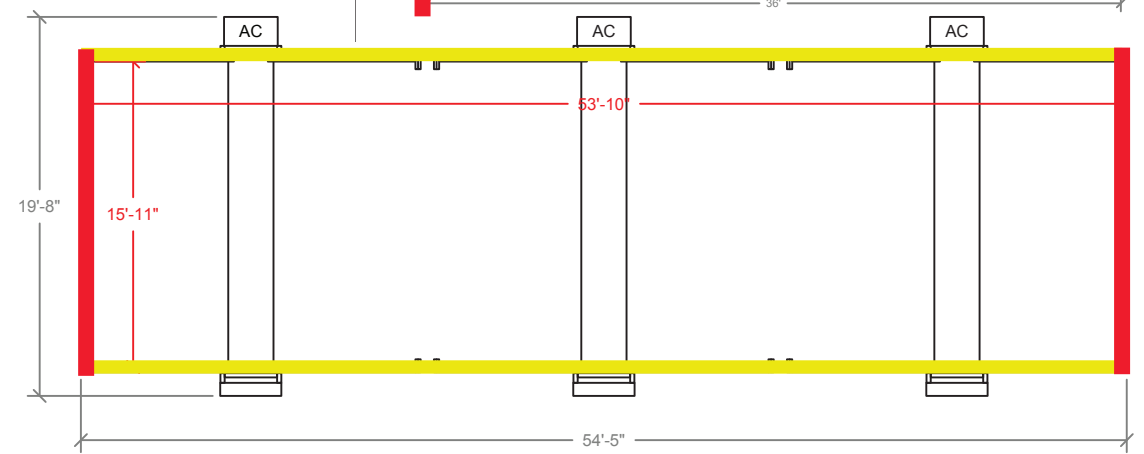

ALPHA WALL



BETA WALL

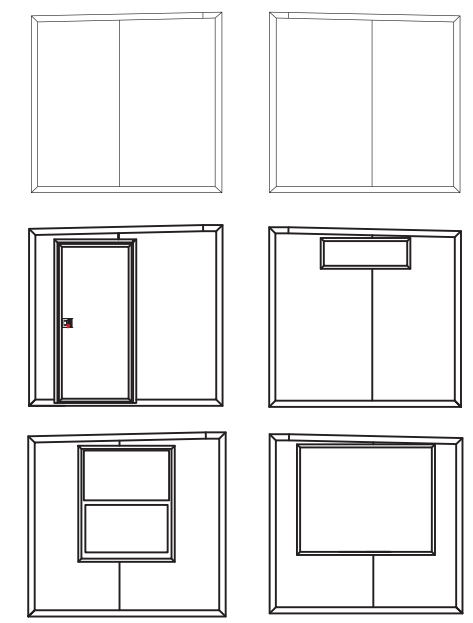

CONTACT US (786) 942 - 4389 | info@fortsservices.com | fortsservices.com