

Lab

Advantages

- *Our quality control process allows for a clean and sterile unit*
- *Secure and private, allowing for a sincere lab feel*
- *Take up minimal space to treat the maximum amount of people*
- *2-ton HVAC for a climate-controlled environment*
- *Insulated/ thermally broken panels to maintain temperature*
- *Get out of the elements and into a comfortable unit for all medical needs*
- *ADA compliant accessibility*
- *16ft wide footprint to maximize layout*
- *Keypad lock system*
- *Optional furniture packages*
- *Secure storage options*

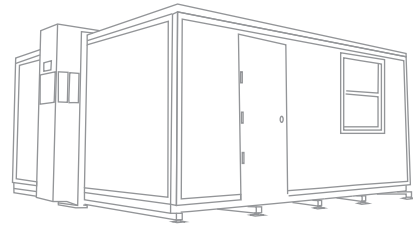



Up To 180 Mph

Up To 4 FORTS Units Per Truck

Leveled+ Assembled On Any Surface

Built-in HVAC, Lighting, Data, Power Outlets

Energy Efficiency + Environmentally Friendly

Rapid 15 Minutes Set-up

Easily Maneuverable

4,000 lbs per FORTS Unit

Branding Options Available

FORTS SYSTEMS

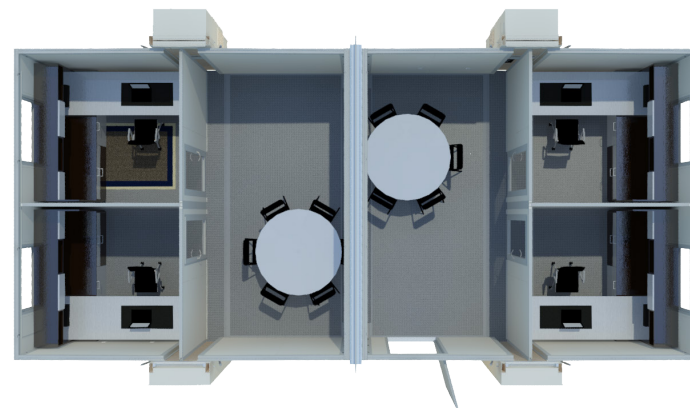

MULTIPLE INTERIOR LAYOUT OPTIONS

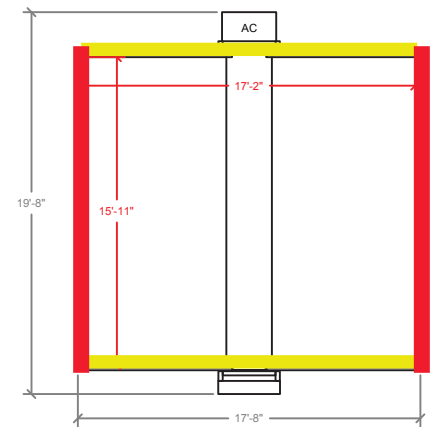

SINGLE UNIT

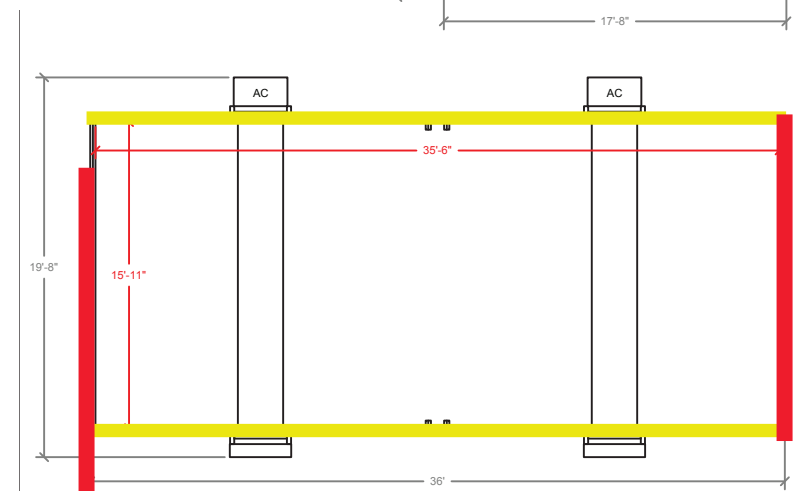

TANDEM

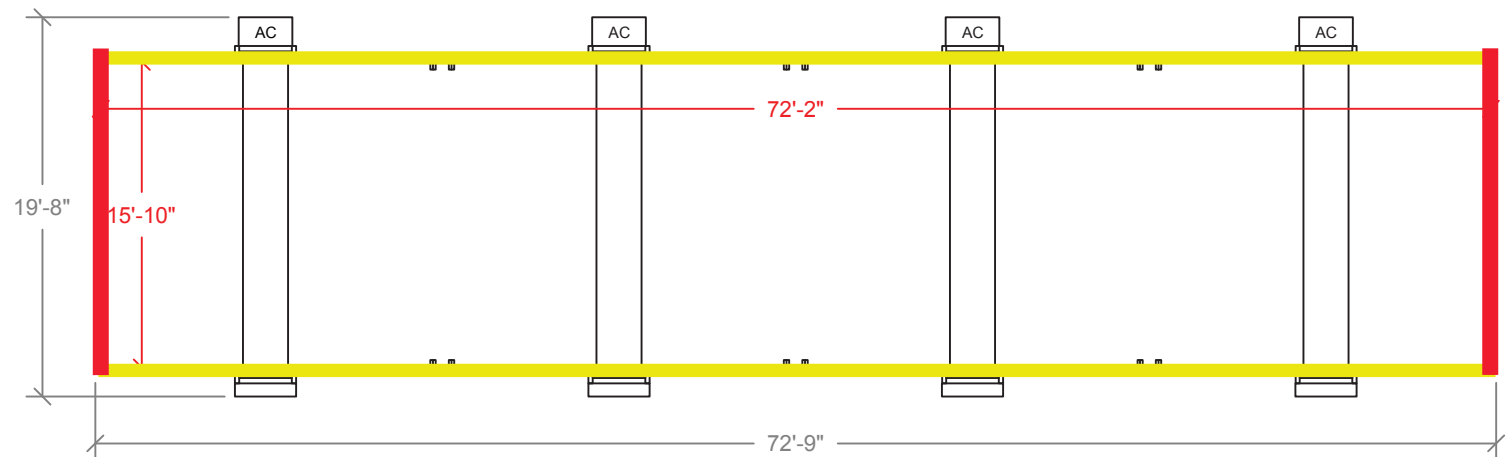
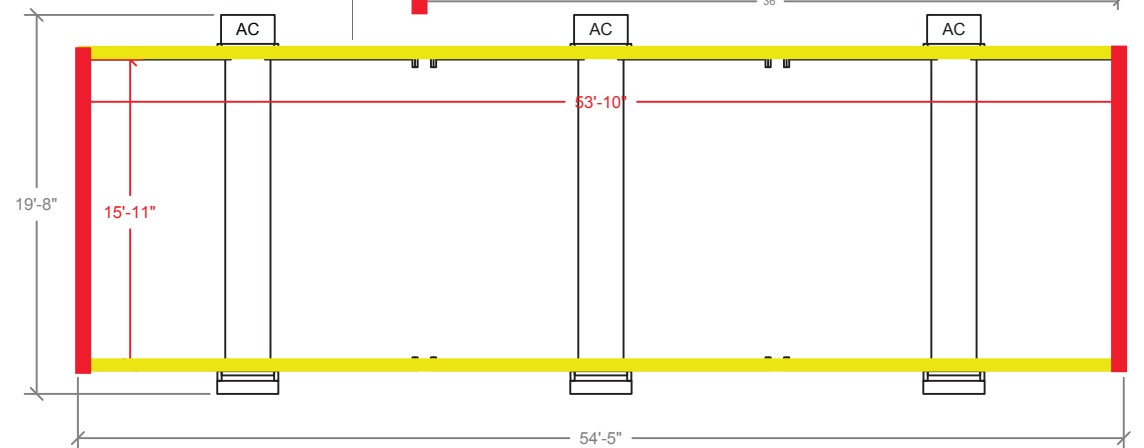

ALPHA WALL



BETA WALL



CONTACT US (786) 942 - 4389 | info@fortsservices.com | fortsservices.com